

K-PUS Micro

Digital Magnetic Compass



K-PUS Micro DMC Sensor

High performance Heading, Bank and Elevation

K-PUS Micro is high accuracy and high performance Digital Magnetic Compass (DMC) sensor family. It measures Bank (Roll) angle, Elevation (Pitch) angle and Heading (Yaw) angle. It includes a 3D accelerometer, a 3D gyroscope and a 3D magnetometer as its primary sensors.

K-OPTO PUS combines technologies of inertial sensors with optical image tracking resulting in a robust and reliable 3DOF orientation module capable of operation in virtually any environment. With the addition of optical image tracking the system is now able to mount directly to a device under measure.

- **Advanced sensor fusion algorithms for accurate calculation of the roll, pitch and yaw angles.**
- **State-of-the-art hard and soft iron calibration algorithms for maximum heading accuracy.**
- **Lightweight and reliable design, ready for use in civilian and military applications.**
- **Numerous modes, settings and options for utilization with great flexibility.**
- **Direct replacement for existing DMC products.(With same mechanical,electronic and software interface,same standart 12-point calibration and easy calibration modes)**

Roll/Pitch Accuracy	Heading Accuracy
0.1° RMS	0.25° RMS

K-PUS MICRO SPECIFICATONS

SYSTEM PERFORMANCE PARAMETERS	
	K-PUS-MICRO
Roll/Pitch Accuracy	0.1° RMS
Heading Accuracy*	0.25° RMS
Pitch/Roll Operational Range	- 80° / + 80°
Sampling Rate	Up to 50 Hz
Pitch/Roll Max Range	- 90° / + 90°
Heading Range	- 180° / + 180°

*Values may change due to magnetic distortion and metal objects around the system. Typical heading accuracy is 0.1°

PHYSICAL AND ELECTRICAL PROPERTIES	
Communications Interface	UART TTL
Power Supply	5 V (± %5)
Dimensions	31x23x8.5mm
Sampling Rate	1 to 50 Hz
Weight	< 11 gr
Power Consumption	160 mW
Operating Temperature	-32°C to 65°C

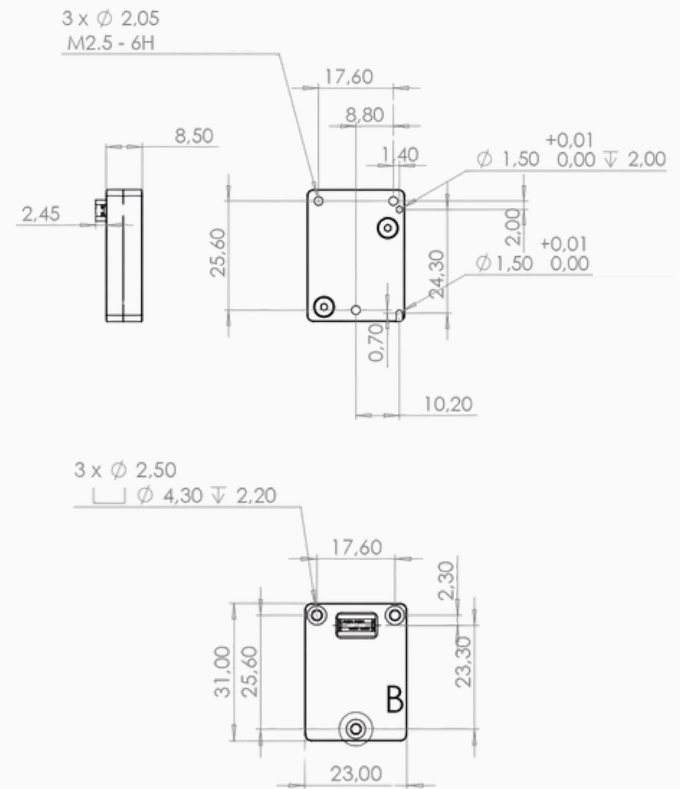

K-PUS Micro series mechanical drawing dimensions are in mm